

NOTES:
 FOR ADDITIONAL INFORMATION ON GUARD RAIL, SEE STANDARD PLANS FOR HIGHWAY GUARD RAIL (MASH).
 FOR CURB & TRANSITION INFORMATION, SEE STANDARD PLANS FOR HIGHWAY GUARD RAIL (MASH), SHEET 3 OF 11.

ALL MATERIALS AND LABOR REQ'D. TO PLACE THE GUARD RAIL THRU THE BRIDGE SHALL BE PAID FOR UNDER ITEM 704-06-00200.

IF THE EXISTING CONCRETE IS DAMAGED DUE TO DRILLING HOLES FOR BOLTS AND RODS, THE CONTRACTOR SHALL REPAIR THE DAMAGE WITH THE APPROPRIATE MATERIALS AT HIS EXPENSE AND TO THE SATISFACTION OF THE PROJECT ENGINEER.

EXISTING HANDRAIL SHALL BE REMOVED AND DISPOSED OF BY THE CONTRACTOR AS DIRECTED BY THE PROJECT ENGINEER.

ALL HOLES (VERTICAL OR HORIZONTAL) DRILLED INTO AN EXISTING CONCRETE STRUCTURE SHALL BE 3/4" IN DIA. THEY SHALL BE CLEANED WITH COMPRESSED AIR AND MADE FREE OF ANY OIL OR RESIDUE. HOLES SHALL BE FILLED WITH EPOXY INJECTION SYSTEM AS LISTED ON APPROVED MATERIALS LIST, PRODUCT CATEGORY "CONCRETE ANCHOR SYSTEMS." PLACE ROD IN HOLE IMMEDIATELY AND WAIT FOR THE MANUFACTURERS CURE TIME.

THE LOWER BOLTS IN THE GUARD RAIL AT EACH POST SHALL BE ON THE ONCOMING TRAFFIC SIDE.

IF TIMBER BLOCKS ARE LESS THAN 3' ABOVE THE CONCRETE RAIL IN THE SOLID RAIL ALTERNATE, THE METHOD SHOWN IN THE POST AND RAIL BRIDGE RAIL ALTERNATE SHALL BE UTILIZED.

THE LENGTHS OF THE LAG SCREWS SHALL BE VERIFIED BY THE PROJECT ENGINEER BEFORE INSTALLATION TO ACHIEVE THE PENETRATION CALLED FOR IN THE SOLID WALL ALTERNATE.

IF APPROACH SLAB FLARES EXIST, A 1'-0" X 1'-0" HOLE SHALL BE CUT THRU THE CONCRETE IN THE PROPER LOCATION TO INSTALL POST. AFTER POST IS IN PLACE, COMPACT SOIL AROUND POST AND REDRESS THE SLAB WITH CONCRETE TO THE FINISHED ELEVATION. (NO DIRECT PAY).

ALL 3/8" BOLTS SHALL BE ASTM A307.

Δ 3/8" Ø LAG SCREW (WITH PLATE WASHER) SHALL PENETRATE TO THE BACK OF THE REAR BLOCK (LENGTH TO BE DETERMINED IN THE FIELD)

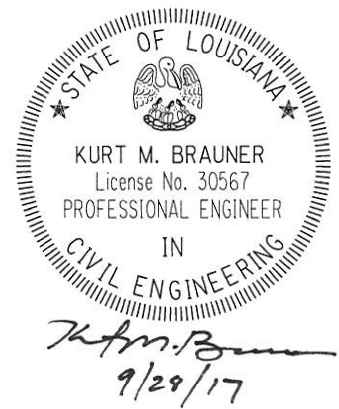
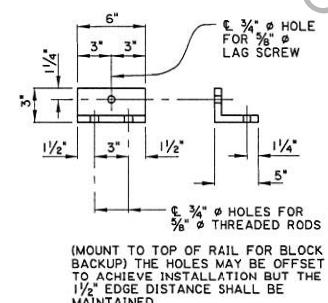
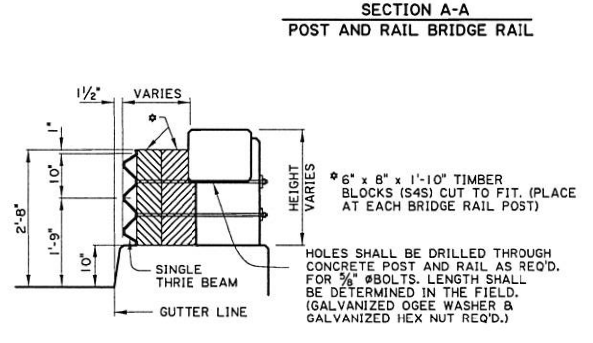
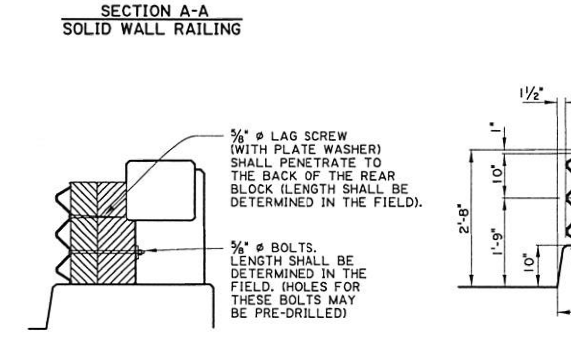
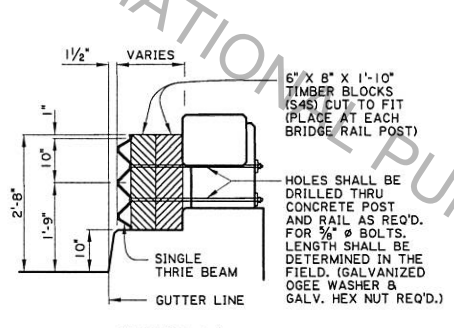
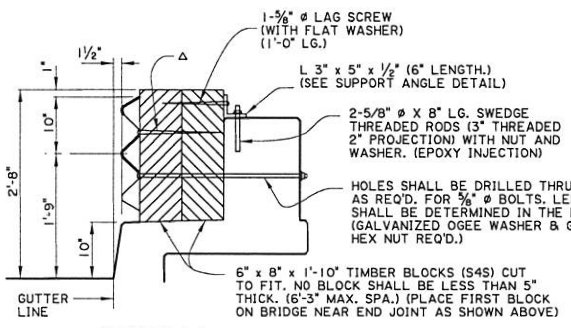

BRIDGE AND STRUCTURAL DESIGN	DIVISION OF TRANSPORTATION AND DEVELOPMENT DOTD FOR USE WITH HIGHWAY GUARD RAIL (MASH)	STATE OF LOUISIANA PROFESSIONAL ENGINEER	DESIGNED	P. FOSSIER	PARISH	SHEET NUMBER
			CHECKED	C. GAUDRY	CONTROL SECTION	
GUARD RAIL TERMINATING ON BRUSH CURB BRIDGE RAIL (TIMBER POST OPTION)		NO. DATE REVISION OR CHANGE ORDER DESCRIPTION BY		DETAILED CHECKED REVIEWED SERIES #	STATE PROJECT	